

Ratiomatic Burners

Model 50RM (Version 2.01)

Specifications

Maximum Input (Btu/hr)	Capacity	Chamber Pressure ("w.c.)
Note: Capacities given without air filter. Contact factory for chamber pressures outside the range -2.0" to 2.0" w.c. or varying chamber pressure conditions.	610,000	-2.0
	560,000	-1.0
	500,000	0.0
	430,000	1.0
	350,000	2.0
Minimum Input (Btu/hr)	20,000 with U.V. scanner flame safety and neutral chamber pressure	
Gas Inlet Pressure ("w.c.) • Fuel pressure at ratio regulator inlet	Nat. Gas	14 to 20
	Propane	14 to 20
	Butane	14 to 20
High Fire Flame Length (Inches) • Measured from the end of the combustor. Contact your local Eclipse representative for details.	Nat. Gas	20
	Propane	20
	Butane	20
Max. Chamber Temp./Alloy Tube (°F)	1,500	
Piping	N.P.T. or B.S.P. burner piping available.	
Flame detection	U.V. scanner only; scanner must be ordered separately.	
Fuel	Natural Gas Propane Butane	For any other mixed gas, contact Eclipse for orifice sizing.
Control Motor Requirements	90° travel with full stroke timing of 12 seconds or longer. Ovens with chamber pressures outside the range -2.0 to +2.0" w.c. will require control motors with less than 90° stroke. See Bulletin 720.	

- All inputs based on gross calorific values.
- Eclipse reserves the right to change the construction and/or configuration of our products at any time without being obliged to adjust earlier supplies accordingly.

Component Information

Air Filter Assembly	Recommended. Grille is supplied if not ordered.	100641
Replacement Filter Element	_____	11846
Spark Plug	Used with 8.4" combustion tube Used with 11.4" combustion tube Used with 14.4" combustion tube Used with 17.4" combustion tube	100115-1 100115-2 100115-3 100115-4
Alloy Combustion Tube	8.4" long 11.4" long 14.4" long 17.4" long	14887-1 14887-2 14887-3 14887-4
Gasket	Burner Mounting	14569
Blower Motor	60 Hz, 115/230v, 1 phase, 1/4 hp 3350 rpm 50 Hz, 110/220v, 1 phase, 1/4 hp, 2850 rpm	14884 16039
Ratio Regulator	Eclipse ES 365, 3/4" NPT Eclipse ES 365MK, 3/4" BSP	19997 19998
Control Motor Mounting Bracket	Upright bracket Inverted bracket Eclipse actuator mounting kit Honeywell actuator mounting kit	14911 16029 100643 100639

Dimensions

Upright 50RM with optional air filter & control motor bracket

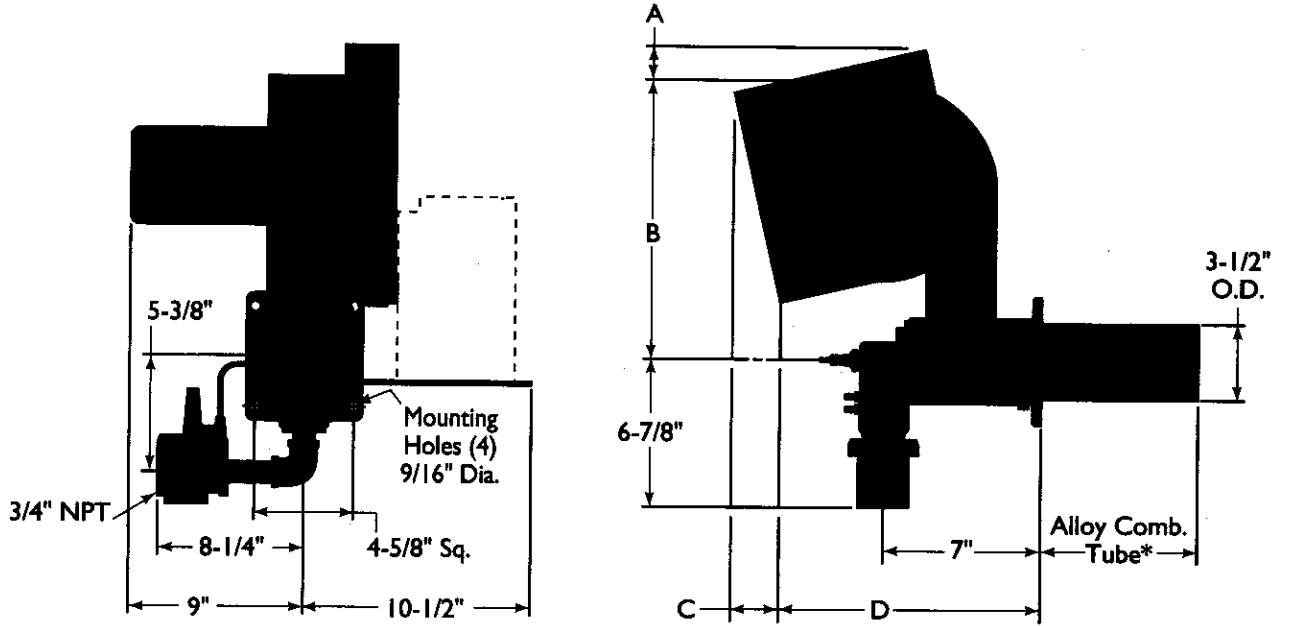

Inverted 50RM with standard air grille & optional control motor bracket

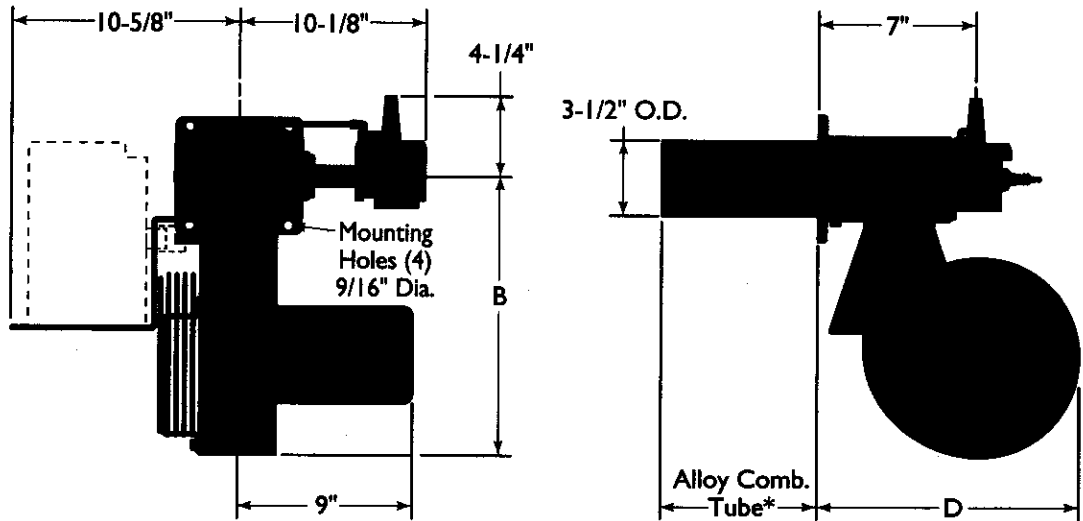

* see Component Information Table on page 2 for alloy combustion tube lengths.

Motor Hz	A	B	C	D
50	1-5/8	14-1/4	1-7/8	13-7/8
60	1-1/2	12-3/8	2-1/2	12-1/2



Offered By:

Power Equipment Company
2011 Williamsburg Road
Richmond, Virginia 23231
Phone (804) 236-3800
Fax (804) 236-3882

www.peconet.com